

The GENERAL RADIO EXPERIMENTER

VOL. X. No. 6



NOVEMBER, 1935

ELECTRICAL COMMUNICATIONS TECHNIQUE AND ITS APPLICATIONS IN ALLIED FIELDS

WAVEFORM ERRORS IN THE MEASUREMENT OF POWER TRANSFORMER LOSSES

ALTHOUGH nearly every communications engineer has, at one time or another, been concerned with

the design of power-supply equipment, he seldom considers the results of harmonic distortion at commercial power frequencies. Iron-core circuit elements, however, are non-linear, and, while either voltage or current may be sinusoidal, both quantities never are.

In the design of power transformers one of the factors which must be taken into consideration is the magnitude of the no-load losses. These are commonly determined by measurement with a wattmeter as a function of the voltage applied to an ex-

perimental winding on the type of core which is to be used in the final product. From these measurements the voltage per turn at the desirable

operating point can be calculated, yielding a basis for determining the final winding data.

It is necessary that the performance of this experimental winding be determined with a sinusoidal voltage impressed on the coil, since the final design will be used on a circuit of essentially sinusoidal voltage.

HARMONIC distortion is a phenomenon constantly dealt with by the communications engineer. It is by means of distortion in non-linear circuit elements that modulation, demodulation, and frequency multiplication are made possible. On the other hand, distortion is one of the most easily neglected sources of error in electrical measurements at communication frequencies. *Experimenter* readers will recall Mr. Thiessen's discussion of waveform errors in filter measurement published in the March, 1935, *Experimenter*. The present article discusses a similar type of error in power transformer measurements.

Figure 1 (a) shows a simple circuit for measuring the no-load losses by means of a wattmeter and a series rheostat to reduce the line voltage. The results of a series of measurements made with this circuit on a

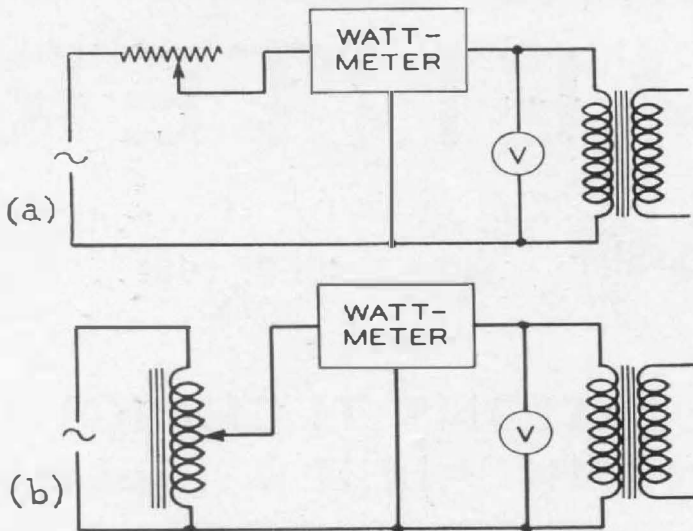

FIGURE 1. (a) Circuit for measuring the no-load loss of a power transformer using a series rheostat to vary line voltage. (b) Similar circuit using the *VARIAC*

sample winding yielded the lower of the two curves shown in Figure 2. When, however, a *VARIAC*, connected as indicated in Figure 1(b), was used to reduce the line voltage, the upper curve of Figure 2 resulted. Since the losses as measured when using the rheostat were some 50% lower than those obtained using the *VARIAC*, the waveforms of current and voltages in the two circuits were examined in order to determine which (if either) of the curves was correct.

To do this the circuit of Figure 3 was set up. With the *VARIAC* and

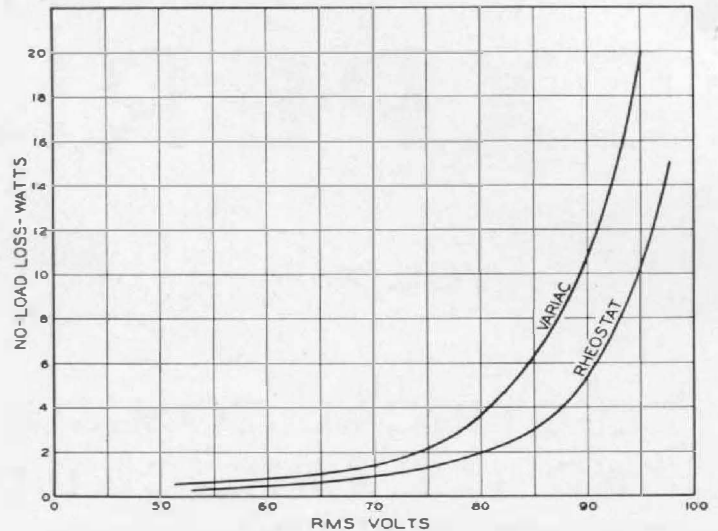

FIGURE 2. Power loss curves obtained by measurement using the circuits of Figure 1. Note that the results differ by 50%

the rheostat adjusted to give the same r-m-s voltage as read on the voltmeter *V*, the oscillograms of Figure 4 and Figure 5 were obtained. Figure 4 shows the voltage and current when the *VARIAC* was used. It will be noted that the voltage is sinusoidal and the current, as a result of the non-linearity of the magnetization curve of the iron, is highly distorted, containing a large third harmonic. Similar oscillograms for the rheostat circuit (shown in Figure 5) indicate that both the current and voltage are non-sinusoidal.

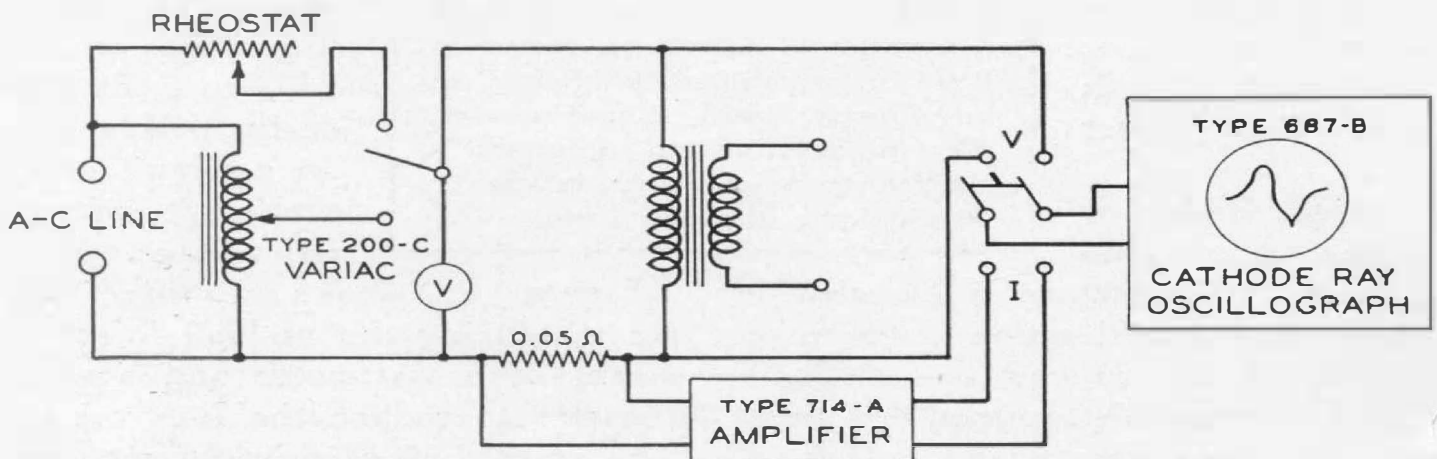

FIGURE 3. Circuit used to obtain the oscillograms of Figure 4 and Figure 5. The 0.05-ohm resistor supplies a voltage drop which is amplified to obtain the current wave shape

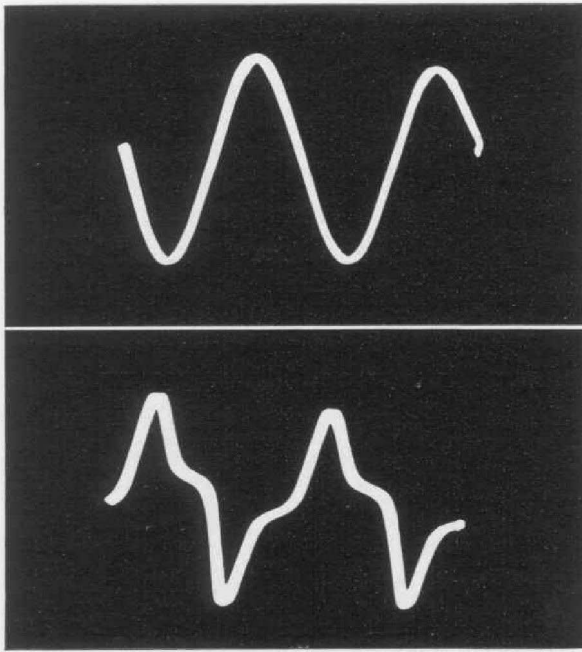

FIGURE 4. Voltage (upper) and current (lower) in the transformer primary when the *VARIAC* is used. The voltage is sinusoidal and the current distorted

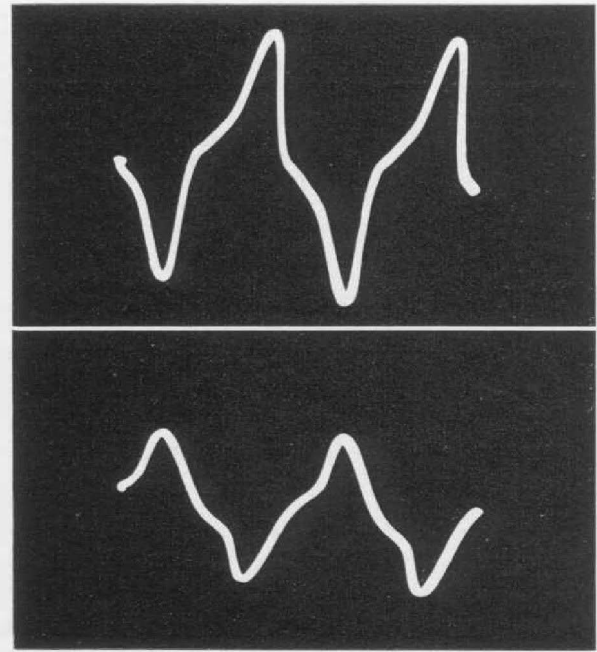

FIGURE 5. Voltage (upper) and current (lower) when the rheostat is used. Both curves are non-sinusoidal and the current is lower than in Figure 4

The reason for this is obvious upon further consideration of the circuit. The non-sinusoidal current produces an IR drop of similar waveform in the rheostat I . Since the voltage impressed on the transformer is the difference of the sinusoidal line voltage and the distorted IR drop, this voltage must also be distorted.

The net result as seen by the oscil-

lograms is a considerably lower current when the rheostat is used. Both core loss and copper loss depend upon current, and the power consumed is therefore less than in the *VARIAC* arrangement.

The *VARIAC*, since it duplicates the desired operating condition of sinusoidal line voltage, gives the correct result.



A NEW MODEL OF THE EDGERTON STROBOSCOPE

A REDESIGN of the TYPE 548-A Edgerton Stroboscope has recently been made in order to incorporate certain improvements and to utilize a more modern rectifier tube, the 83-type. Chief result of the redesign is a greater range of flash speeds. The new model, TYPE 548-B, can be used reliably at speeds slightly in excess of 200 per second.

Other specifications are unchanged and the price remains at \$290.00.

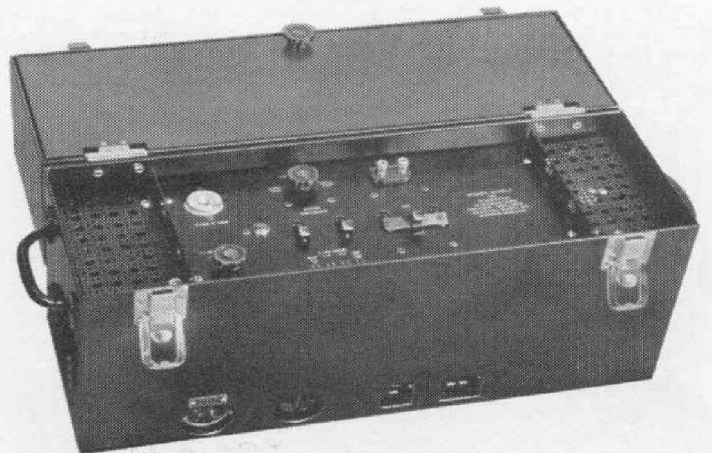

THE EDGERTON STROBOSCOPE

STROBOSCOPY in the industrial field has reached its present state of excellence largely through the efforts of Professor Harold E. Edgerton of Massachusetts Institute of Technology. Professor Edgerton and Mr. Kenneth Germeshausen are responsible for the fundamental development underlying the three types of General Radio stroboscopes.

In addition to the Type 548-B Stroboscope described herewith, the General Radio Company manufactures the Type 631-A Strobotac, a neon-lamp instrument intended primarily for speed measurements, and the Type 621 Edgerton Power Stroboscope, a high-power instrument suitable for taking high-speed motion pictures in conjunction with the Type 651-A Camera.

THE TYPE 548-A Edgerton Stroboscope, now approaching its third birthday, has already achieved a position of some importance in the industrial scene.

The study of high-speed motion which the design and maintenance of modern machinery requires can be satisfactorily made only by the strobo-

scopic method. The Edgerton Stroboscope, because of its brilliant, short flash, has readily found its way into fields where older types of stroboscopes were not acceptable, and it is used today in some part of the design or manufacture of machines, automobiles, engines, instruments, cameras, electric motors, metal products, and textiles. The fact that some twenty engineering schools and universities are users of this instrument is further evidence of its utility in mechanical and electrical engineering.

The accompanying photographs, taken in the laboratories of the Emerson Electric Manufacturing Company, makers of motors, fans, and electrical specialties, are an excellent example of the use of the stroboscope in industry. For manufacturers of this type of product, the stroboscope is not only a means of laboratory testing on new products but is also the key to better design and more satisfactory performance. Emerson engineers have found it the only satisfactory method of determining the vibration and distortion of fan blades and hubs.

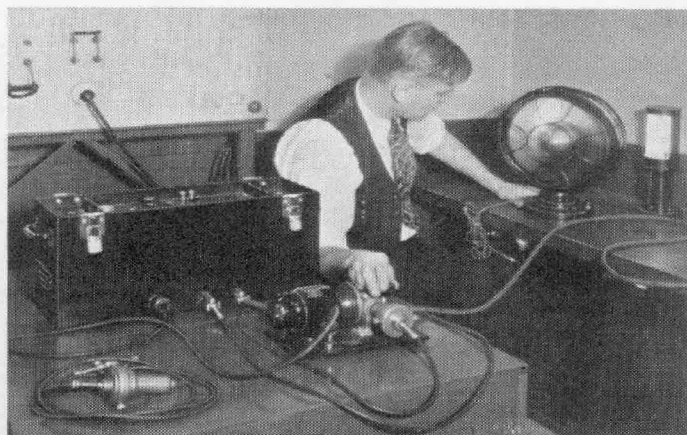
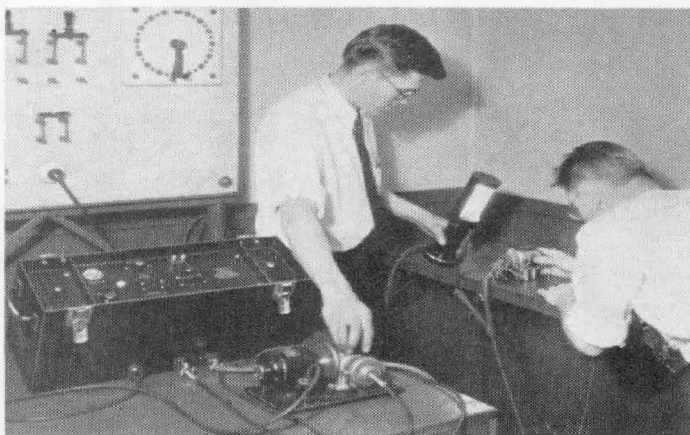

Photographs, Courtesy Emerson Manufacturing Company

TYPE 559-B NOISE METER

ALTHOUGH heralded by ballyhoo which might have ruined a less hardy child, the cause of "noise abatement," joint offspring of the social and the physical sciences, continues to flourish and shows distinct promise of a long and useful career.

In the factory, the office, and the store, noise reduction receives more and more attention as employers realize that noise takes its share of nervous energy with a consequent reduction in efficiency. Far less attention would be paid to critics of the machine age if its identifying characteristic were not the clatter and din of machinery.

FOR industrial noise measurement and noise-level surveys, the noise meter is the most convenient instrument to use. It combines a reasonable accuracy with low cost, rugged construction, and portability.

The TYPE 559-A Noise Meter, announced in March, 1933,* was one of the first low-priced noise-measuring instruments available. Its reference level was the average threshold of hearing at 1000 cycles, since this level was used by many investigators at that time. It is only recently, however, that there has been any degree of standardization in this respect, and at present the tendency seems to be to favor a reference level approximately 7 db lower, which represents the threshold of hearing for a person whose hearing is unusually acute. This new reference level, as recommended by the American Standards Association, is 10^{-16} watts per square centimeter at 1000 cycles.

*"Commercial Noise Measurement," H. H. Scott, *General Radio Experimenter*, March, 1933.

The actual reference level of a noise meter is not particularly important, since the readings may be referred to any desired level by merely adding or subtracting a fixed number of decibels, but standardization is desirable since it eliminates the necessity of corrections between different instruments.

In order to promote standardization in noise measurements, the General Radio Company is announcing a modified noise meter, known as TYPE 559-B. This differs from the earlier model mainly in that the new reference level is used, with the result that, on any given sound, the new meter reads 7 db higher than the old one. The over-all sensitivity has also been increased to the extent of 3 db. Accordingly, the new noise meter covers the range from 34 db to 150 db above 10^{-16} watts per square centimeter at 1000 cycles. Users of the TYPE 559-A Noise Meter can, of course, compare their readings with the new reference level by merely adding 7 db.

—H. H. SCOTT

The description of the TYPE 559-A Noise Meter published in our current catalog applies, in all particulars except reference level and range, to the new model. The price remains unchanged at \$190.00.

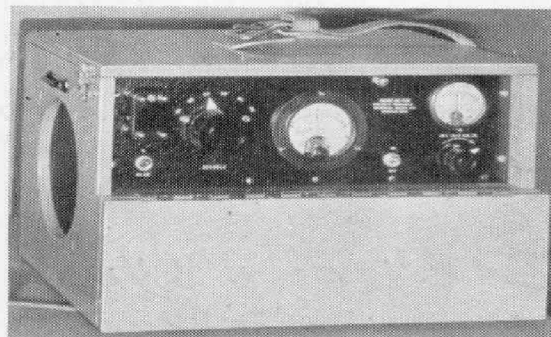

USES OF THE VARIAC

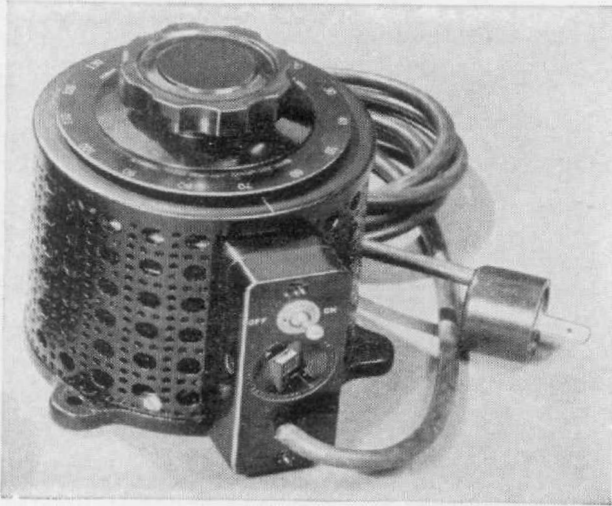

To determine the market and applications of the *VARIAC*, we recently made a survey of a small group of customers. In the belief that they will be of interest to our readers, we are publishing the results of this analysis. In view of the wide variety of uses reported, present owners may find suggestions for increasing the usefulness of the *VARIACS* they already have, and others, not acquainted with the versatility of the *VARIAC*, may find a convenient solution to problems involving the control of voltage.

As a sample, a group of 100 invoices for the *VARIAC* representing the latest 100 orders were taken from our files in chronological sequence, with no attempt at selection. A letter was sent to each purchaser asking what use was made of the *VARIAC*. To these 100 letters, 70 replies were received. All but 2 of these indicated, at least in general terms, what use was being made of the instrument, and all but 7 listed specific applications. An analysis of these letters yields some 24 classes of users and 12 classifications of use. Actually, 96

applications were listed, but many of them were listed by more than one customer. These tabulations are given below.

USERS

Electrical Manufacturing	24
Meters	2
Appliances	2
Motors	1
Controllers	2
Transformers	1
Condensers, Resistors	4
Lamps and Vacuum Tubes	7
Radio Receivers	2
Radio Transmitters	3
Other Manufacturing	23
Instruments	8
Machinery	4
Glass	1
Dental	1
Chemical and Metallurgical	6
Petroleum Products	3
Educational Institutions	4
Radio Broadcasting Stations	3
Photo Supply Dealers	3
Electric Power Companies	2
Photographers	2
Research Laboratories	5
Radio Service	1
Operating Communication Companies ...	1
Motion Pictures	2
Total	70

USES

- (1) Voltage control for testing electrical equipment20
(Overload, over-voltage, and under-voltage tests on relays, switches, appliances, radio transmitters, radio receivers, electrical instruments, etc.)
- (2) Power-supply control for testing12
(The *VARIAC* is used in the primary of a high-voltage transformer.)
- (3) Voltage adjustment on vacuum-tube equipment14
(Adjustment of grid bias, filament voltage, plate voltage on radio transmitters, rectifiers, etc., also exhausting equipment in vacuum-tube manufacturing.)
- (4) Voltage control in manufacturing processes other than vacuum tube ... 4
- (5) Heat control in electric furnaces, oil baths, electric heaters, etc.12
- (6) Illumination control in photography. 7
(Used to adjust voltage supplied to enlargers, flood lights, etc.)

(7) General laboratory use	7
(8) Manual adjustment of line voltage to constant value and to boost low voltage.....	3
(9) Electric lamp life tests and demonstrations.....	4
(10) To obtain a wide range of 60-cycle calibrating voltage	4
(11) Motor speed control	3
(12) Miscellaneous	6
a. Demagnetizing iron.	
b. Avoid overload in experimental circuits by increasing voltage gradually.	
c. Soldering iron—quick heating.	
d. Modulating voltage for transmitter tests.	
e. Regulate output of electrotherapeutic equipment.	
f. Motion picture exciter lamp control.	
 Total	 96

The users' classification shows that some 33% of these 70 customers are engaged in electrical manufacturing and 31% in other branches of manufacturing.

The use classification tells us what these 64% do with the *VARIAC*. Items (1) and (2), amounting to 33% of the total uses submitted, are in electrical testing, nearly all by manufacturers. Items (4), (5), (11), and a portion of (3) are a part of manufacturing processes, totaling 22%.

Nearly every electrical product, whether intended for industrial or consumer use, must be tested above and below its normal operating voltage, and accordingly we find that the largest individual item is (1) which covers this field.

The most important single use of the *VARIAC* in the manufacturing process itself is the control of heat. Item (5), which covers both manufacturing and laboratory heaters, is 13% of the total.

Grouping these items in another way, in 70% of the uses, the primary

object is the control of voltage; in 30% some other quantity, such as heat, illumination, or speed, is controlled by means of voltage.

A third grouping can be made by separating the total into two main classes. In the first, the primary object is to vary voltage, in the second, to hold it constant by manual adjustment. While it is difficult to make an exact analysis from the data in the USES table, it appears that in about 75% of the uses the voltage is varied, and in 25% it is held constant.

While it is not evident from either of the above classifications, one additional grouping might be made, a division between those used by the purchaser and those built into equipment for resale. A large number of the *VARIACS* used in radio transmitters and electrical controllers are used as an integral part of larger assemblies and resold.

One of the most interesting aspects of the analysis was the diversity of use reported. Although the *VARIAC* has been on the market a relatively short time—our patent* on the principle having just recently been issued—the number of uses listed exceeds appreciably the number of replies received to our questionnaire. In other words, the average number of applications per user reporting was approximately 1.4. Generalizations drawn from limited data are, of course, not conclusive, but the ready acceptance and wide range of usefulness of the *VARIAC*, as indicated by the survey, undoubtedly predicts for the *VARIAC* an industrial career of considerable importance.

*U. S. Patent No. 2,009,013.

RELAY-RACK MOUNTING FOR THE ELECTRON OSCILLOGRAPH

FOR the three branches of electrical engineering — education, manufacturing, and research — the cathode-ray oscillograph has been a tool of inestimable value. Although the merit of its high-impedance and practically inertia-less element has long been recognized by the research workers, it is only in the last few years that modern vacuum tube production and the simplified design of linear-time-axis circuits have made it a serious competitor of the vibrating-element oscillograph. Recent papers on multi-element operation by means of commutation point the way to a still wider use at commercial power frequencies, as well as in the communication field.

To the fields invaded by the electron oscillograph, advertising must now be added. Although Braun would undoubtedly have had difficulty in visualizing any connection between his discovery and the manly art of shaving, the cathode-ray oscillograph appears as a research tool in the current advertising of the Gillette Safety Razor Company.

permits rear-of-panel interconnections.

Many General Radio instruments are supplied for relay-rack mounting; others can be converted for rack mounting if desired. The TYPE 687-A Cathode-Ray Oscillograph, not heretofore available in rack mounting, has recently been redesigned to facilitate this conversion.

The new models, TYPE 687-BM and TYPE 687-BR are identical in their electrical characteristics and specifications with the TYPE 687-A instrument, and the changes consist mainly of a mechanical rearrangement of parts. The relay-rack model is not carried in stock as such, but a cabinet model can be converted to rack mounting at the customer's request.

The prices given below are for standard models with fast-screen tubes.

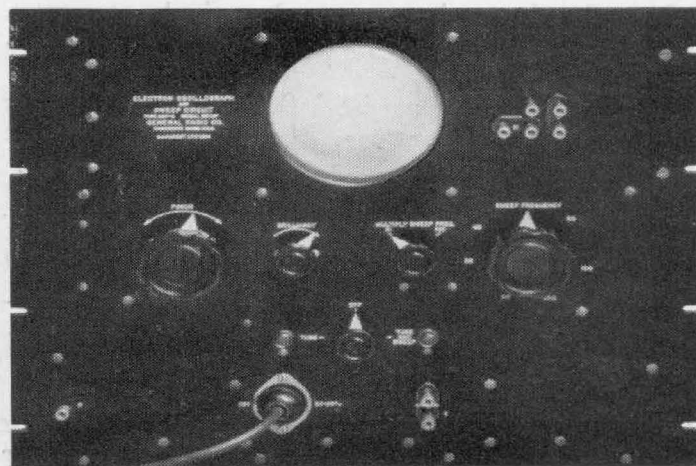

IN the broadcasting station and the test laboratory, in fact in all permanent installations, relay-rack-mounted equipment is widely used. This type of mounting provides maximum accessibility in a minimum space and

Type		Code Word	Price
687-BM	Cabinet Model.....	CRISP	\$184.00
687-BR	Rack Model.....	CALIF	224.00



GENERAL RADIO COMPANY

30 State Street - Cambridge A, Massachusetts

PRINTED
IN
U.S.A.